



M450-LED

Marine Surface Mount Wall **LED**

PRODUCT SPECIFICATION

Surface Lighting M450 Series

The M450 series is designed for berth and bunk lighting in seaborne vessels and offshore platforms.

Mounting

Surface-mounts to bulkheads.

Electrical

High output LEDs powered by 120-277V 50/60Hz driver

Lens

Extruded, impact-resistant, white acrylic lens.

Housing

Extruded aluminum housing with die-cast ends.

Finish

Polyester powder-coated after phosphate pretreatment for superior adhesion and corrosion resistance.

Wiring

Available with a single receptacle outlet and lighted switch.

Certifications

IP 20 rated. USCG ABS approved. UL 1598A marine listed.

Applications

- Bunks, bulkheads
- Mirror lights
- Passageways
- Chart lights

Job Name _____

Fixture Type _____

Catalog No. _____

Approval _____

Date _____

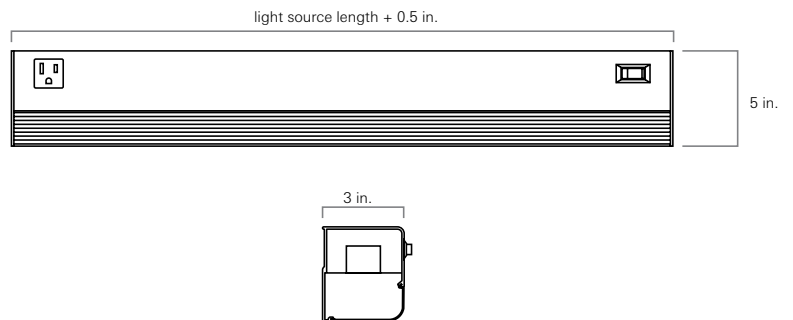

M450	one	two
------	-----	-----

one	LED Wattage / Length
LED12	12 in. 4W LED, 480 lumens, 4000K standard
LED18	18 in. 9.6W LED, 840 lumens, 4000K standard
LED24	24 in. 7W LED, 840 lumens, 4000K standard
LED36	36 in. 19.2W LED, 1680 lumens, 4000K standard

two	Options
R	Red
CO	Convenience outlet
SW	Switch
USB	USB Charging Port

Modifications are available to meet custom requirements. Specifications and dimensions are subject to change without notice.