



# MIL-DTL-16377/X

900 Series

Single Foundation Overhead Lighting Surface Mount Flush Mount 10W-30W LED

PRODUCT SPECIFICATION

## Overhead Lighting 900 Series

The 900 Series is a single foundation watertight LED luminaire designed for general purpose naval lighting in wet maritime environments. Available with a 5-hour EM (NEALS) battery system.

### Mounting

Mounts to ceiling surface or flushed within them. Legacy dual foundation mounting available for M16377/8, M16377/11 and M16377/12.

### Light Source

One LED array, powered by 120V 60Hz drivers, provides 10W-30W of solid state illumination.

901 series - 10W M16377/8 SYM 331.1 Lumen output

902 series - 20W M16377/11 SYM 77.4 Lumen output

903 series - 30W M16377/12 SYM 333.1 Lumen output

### Lens

0.187 in. thick white diffusing lens.

### Housing

Die cast aluminum.

### Finish

Polyester powder-coated after phosphate pretreatment for superior adhesion and corrosion resistance.

### Weight

901-902 series

5 lbs. 14 oz. (standard model), 6 lbs. 4 oz. (EM model) without cable

903 series

6 lbs. 7 oz. (standard model) 6 lbs. 13 oz. (EM model) without cable

### Cable

Supplied with 10 ft. of low smoke cable.

### Certifications

First Article Qualified.

IP67 rated. USCG ABS approved.

Contact factory for additional options.



901,902 & 903 series

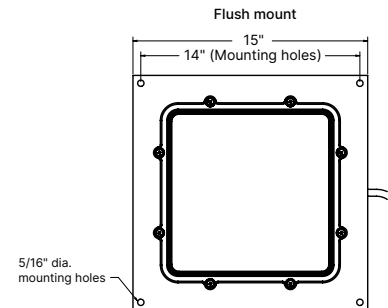
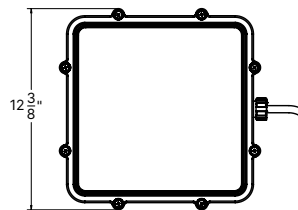
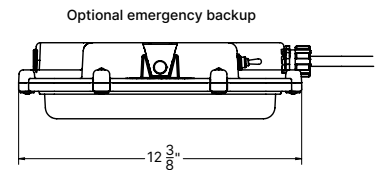
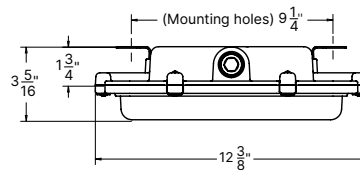

5/16" dia. mounting holes



SERIES      one                      two                      three                      four                      five

Series	one	two	three	Wattage	four	Switch option(s)
901	F	Flush mount		Red Only	S	One DPST switch
902			5	5 Watts		
903			10	10 Watts		
	two	LED Color Array	15	15 Watts	five	Options
	R	Red/White			EM	NEALS emergency battery backup
	NV	Night Vision/White			LC	Less Cable
	PR	Pure Red <i>no white</i>	8	8 Watts		
	PNV	Pure Night Vision <i>no white</i>	16	16 Watts		
			24	24 Watts		

Modifications are available to meet custom requirements. Specifications and dimensions are subject to change without notice.



# MIL-DTL-16377/X

900-LED Series

Single Foundation    Overhead Lighting    Surface Mount    Flush Mount    10W-30W    **LED**

PRODUCT SPECIFICATION

Replacement Item	L.C. Doane Number
LED Array (White Only)	L-LW96
LED Array (White Only), EM	L-LW96-EM
LED Array (White-Red)	L-LW96-R24
LED Array (White-Red), EM	L-LW96-R24-EM
LED Array (White-Nvis Cyan)	L-LW96-NV15
LED Array (White-Nvis Cyan), EM	L-LW96-NV15-EM
Driver, Non-EM	P-900
Driver, EM	P-904
Window Assembly	B-3212
Shockmount Assembly	B-3210-A
Emergency Battery Pack	P-3083