

## M470 Series

### Surface or Recessed Mount Fluorescent Light Fixture

The M470 Series is engineered and constructed specifically for marine installation where unusually severe operating conditions exist. The housing is manufactured of marine grade aluminum. The lens is formed 1/4" thick acrylic. Three, nickel plated, captive screws hold the lens securely to the housing assuring a watertight seal between the lens and housing.

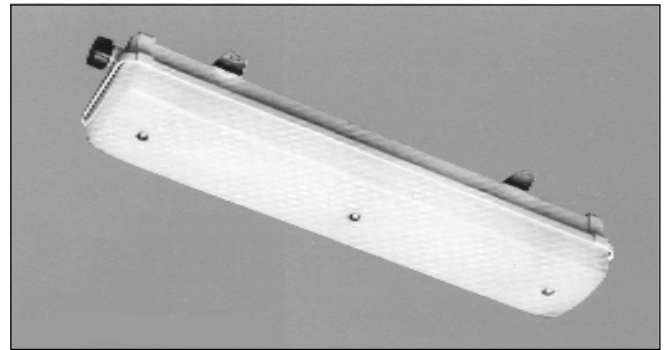

M470 Series, White Acrylic, Surface Mount

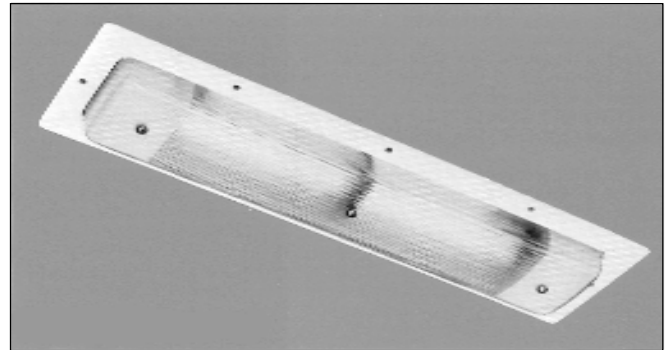

M470 Series, Prismatic Acrylic, Recessed Mount

### Specifications

**HOUSING:** Constructed of marine grade dieformed and cast aluminum. A neoprene gasket is seated in a continuous groove to assure a watertight seal between the lens and the housing. Each fixture has one factory installed stuffing tube.

**LAMP HOLDERS:** Fluorescent lampholders are installed with lamp lock devices to hold the 15W T12 lamps securely in position.

**LENS:** One piece formed 1/4" thick acrylic secured with three nickel plated, captive screws.

**SHOCK MOUNTS:** Zinc plated, corrosion resistant, shock resistant mounting brackets.

**FINISH:** White, powder coat finish, inside and out, phosphate pretreated to ensure superior adhesion and rust resistance.

**BALLAST:** Low power factor type. Operates at 120 volt, 60 Hertz.

**WARRANTY:** 5 years against defective material and workmanship.

### Applications

- **Severe Conditions**
- **Work Areas**
- **Corridors/Stairwells**
- **Engine Rooms**

Watertight lighting fixture  
 Factory Installed stuffing tube  
 1, 2 or 3 lamp combinations  
 Marine Grade U.L. Listed 1598A  
 U.S.C.G.

Modifications are available to suit  
 custom requirements

### How To Order Example: M470-S-W-SW.

|                      |                 |                     |                         |                         |
|----------------------|-----------------|---------------------|-------------------------|-------------------------|
|                      |                 |                     |                         |                         |
| <b>SERIES</b>        | <b>MOUNTING</b> | <b>LENS</b>         | <b>OPTIONAL</b>         | <b>OPTIONAL FILTERS</b> |
| M470 = (1) 15W Lamp  | S = Surface     | W = White Diffusing | SW = Switch             | R = Red                 |
| M472 = (2) 15W Lamps | R = Recessed    | P = Clear Prismatic | SJO = 10' of 16/3 cable | B = Blue                |
| M473 = (3) 15W Lamps |                 |                     |                         | Y = Amber               |

## M470 Series

### Surface or Recessed Fluorescent Light Fixture

**Dimensions** Dimensions and specifications subject to change without notification

#### Surface Mount Dimensions

|               | M470            |      | M472            |      | M473         |      |
|---------------|-----------------|------|-----------------|------|--------------|------|
|               | inches          | (mm) | inches          | (mm) | inches       | (mm) |
| <b>A</b>      | 23-3/16"        | 589  | 23"             | 584  | 23-1/4"      | 590  |
| <b>B</b>      | 2-3/8"          | 60   | 2-1/2"          | 63   | 2-9/16"      | 65   |
| <b>C</b>      | 4-3/4"          | 121  | 7-1/4"          | 184  | 9-1/4"       | 236  |
| <b>D</b>      | 13-7/8"         | 352  | 13-7/8"         | 352  | 13-7/8"      | 352  |
| <b>H</b>      | 1-1/2"          | 38   | 1-11/32"        | 34   | 1-3/4"       | 44   |
| <b>Weight</b> | 6lbs 4oz/2.9 kg |      | 8lbs 11oz/3.9kg |      | 12lbs/5.4 kg |      |

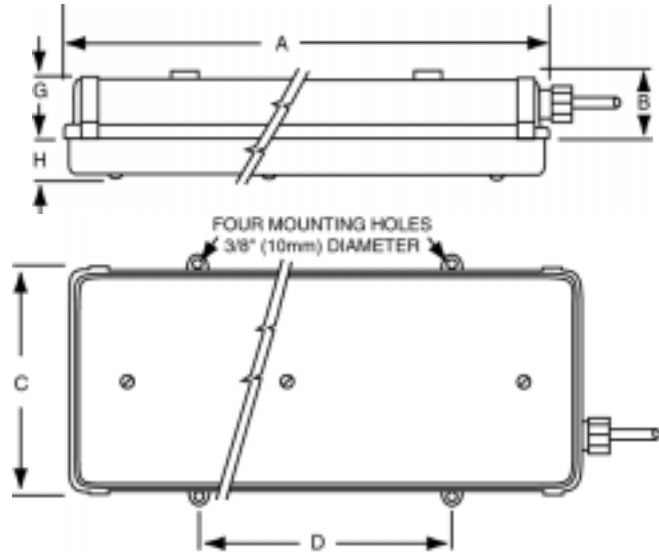

#### Recessed Mount Dimensions

|               | M470           |      | M472            |      | M473             |      |
|---------------|----------------|------|-----------------|------|------------------|------|
|               | inches         | (mm) | inches          | (mm) | inches           | (mm) |
| <b>A</b>      | 23-3/16"       | 589  | 23"             | 584  | 23-1/4"          | 590  |
| <b>B</b>      | 2-3/8"         | 60   | 2-1/2"          | 63   | 2-9/16"          | 65   |
| <b>H</b>      | 1-1/2"         | 38   | 1-11/32"        | 34   | 1-3/4"           | 44   |
| <b>I</b>      | 25-9/16"       | 649  | 25-5/16"        | 643  | 25-5/8"          | 651  |
| <b>J</b>      | 24-5/16"       | 617  | 24-1/16"        | 611  | 24-3/8"          | 619  |
| <b>K</b>      | 12-5/32"       | 309  | 12-1/32"        | 305  | 12-3/16"         | 309  |
| <b>L</b>      | 13-7/8"        | 352  | 13-7/8"         | 352  | 13-7/8"          | 352  |
| <b>M</b>      | 7-1/4"         | 184  | 9-15/16"        | 252  | 11-7/8"          | 302  |
| <b>N</b>      | 6"             | 152  | 8-11/16"        | 221  | 10-5/8"          | 270  |
| <b>P</b>      | 23-9/16"       | 598  | 23-5/16"        | 592  | 23-5/8"          | 600  |
| <b>R</b>      | 5-1/4"         | 133  | 7-15/16"        | 202  | 9-7/8"           | 251  |
| <b>Weight</b> | 8lbs 9oz/3.9kg |      | 10lbs 1oz/4.6kg |      | 13lbs 10oz/6.2kg |      |

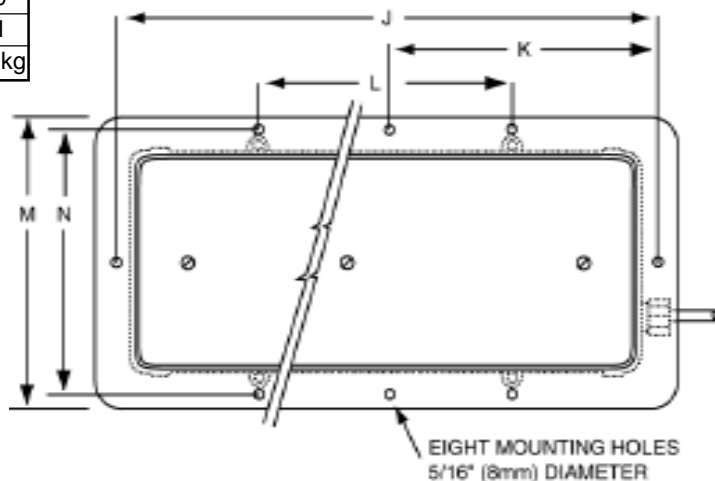
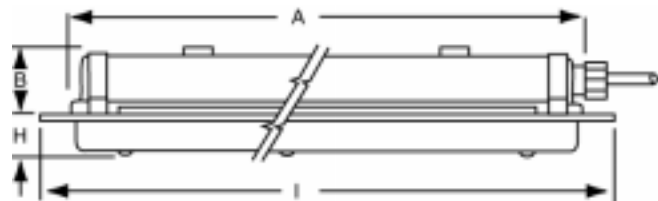

#### Recommended Ceiling Opening

